

INSTALLATION GUIDE

NI CB-37F-LP

Connector Block for 37-Pin D-Sub Devices

This installation guide describes how to install and connect signals to the NI CB-37F-LP connector block for use with devices with a 37-pin D-Sub connector.

Introduction

The CB-37F-LP is a connector block assembly consisting of a printed circuit board and 40 screw terminals. The connector block assembly connects directly to the front panel of National Instruments 37-pin D-Sub devices, eliminating the need for an external cable. It also can be cabled using a 37-pin cable.

The CB-37F-LP allows you to easily connect analog input, analog output, counter/timer, and digital I/O signals to your National Instruments device. The 40 screw terminals allow access to every pin on the connector, plus three shield screw terminals for use with a shielded cable.



Caution The CB-37F-LP is not designed for input voltages greater than $42 V_{pk}$, even if you install a voltage divider that reduces the voltage to within the input range of the DAQ device. Input voltages greater than $42 V_{pk}$ can damage the CB-37F-LP, any device connected to it, and the host computer. Overvoltage also can cause an electric shock hazard for the operator. National Instruments is *not* liable for damage or injury resulting from such misuse.

What You Need to Get Started

You need the following to set up and use your connector block:

- NI CB-37F-LP Connector Block Assembly
- [NI CB-37F-LP Installation Guide](#)
- One of the following:
 - NI 6010 device
 - NI 6510/6516/6517/6518/6519 device
- [NI 6010 Help](#) or [Digital I/O Help for NI 6509/651x/6528 Devices](#)
- 0.10 in. slotted screwdriver
- Wire cutters
- Wire insulation stripper
- Number 1 Phillips screwdriver
- SH37F-37M cable (if not mounting directly to the NI device)

Safety Information



Cautions Do *not* operate the device in an explosive atmosphere or where there may be flammable gases or fumes.

Do *not* operate damaged equipment. The safety protection features built into this device can become impaired if the device becomes damaged in any way. If the device is damaged, turn the device off and do *not* use it until service-trained personnel can check its safety. If necessary, return the device to National Instruments for service and repair to ensure that its safety is not compromised.

Do *not* operate this equipment in a manner that contradicts the information specified in this document. Misuse of this equipment could result in a shock hazard.

Do *not* substitute parts or modify equipment. Because of the danger of introducing additional hazards, do *not* install unauthorized parts or modify the device. Return the device to National Instruments for service and repair to ensure that its safety features are not compromised.

You *must* insulate all signal connections to the highest voltage with which the CB-37F-LP can come in contact.

Connections, including power signals to ground and vice versa, that exceed any of the maximum signal ratings on the connector block can create a shock or fire hazard, or can damage any or all of the boards connected to the host computer, and the connector block. National Instruments is *not* liable for any damages or injuries resulting from incorrect signal connections.

Clean the device and accessories by brushing off light dust with a soft non-metallic brush. Remove other contaminants with a stiff non-metallic brush. The unit *must* be completely dry and free from contaminants before returning it to service.

Connecting the Signals

Refer to the help file for the NI 37-pin device for a list of signals available on the CB-37F-LP.

Refer to Figures 1 and 2 as you complete the following steps to connect signals to the connector block.

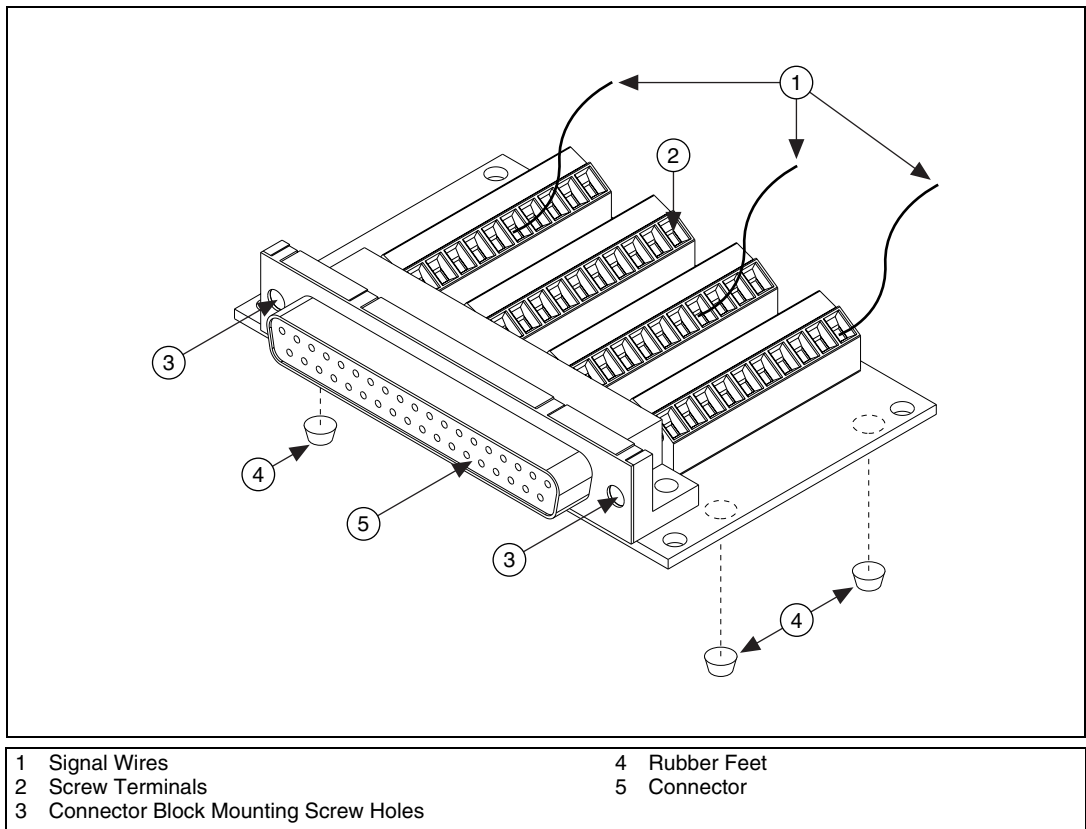

Figure 1. CB-37F-LP Parts Locator Diagram

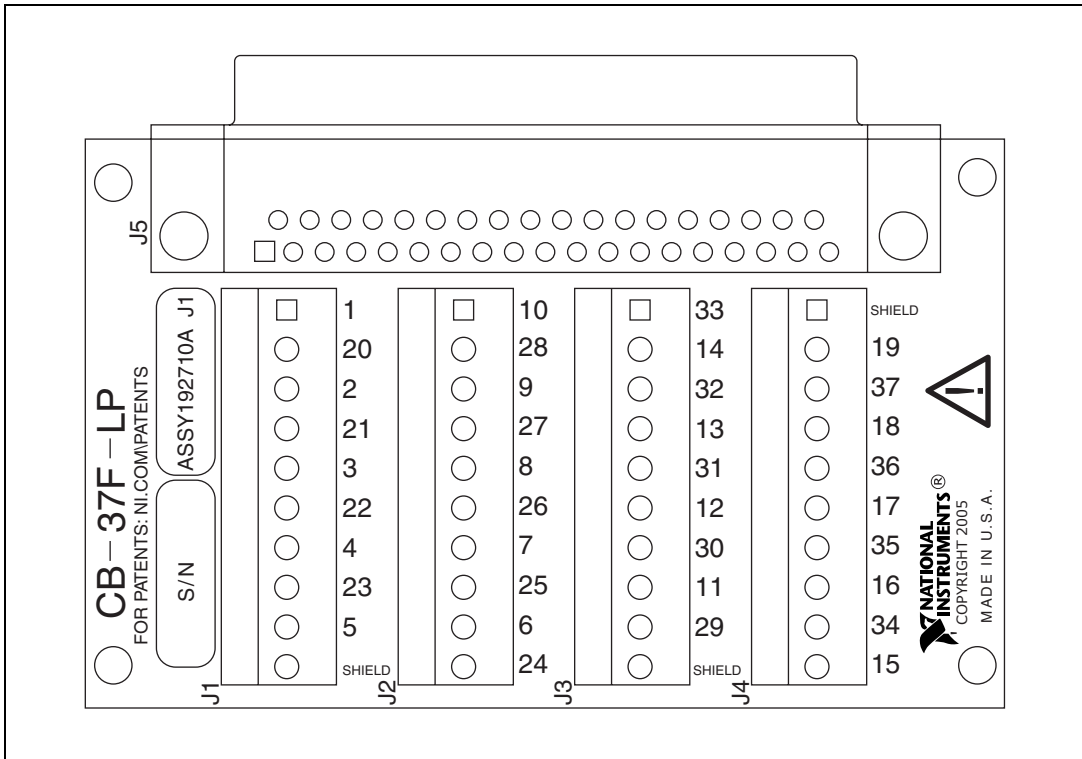

Figure 2. CB-37F-LP Top View

1. Use wire cutters and wire insulation strippers to strip no more than 7 mm of insulation from the wire ends.
2. Loosen the screws in the screw terminals with the 0.10 in. slotted screwdriver.
3. Insert the stripped wires into the screw terminals, and tighten the screws with the 0.10 in. slotted screwdriver. No bare wire should extend past the screw terminal. Exposed wire increases the risk of short circuits and failures.

Mounting the Connector Block to the Device

Refer to Figure 3 as you complete the following steps to mount the connector block on the PCI device I/O connector.

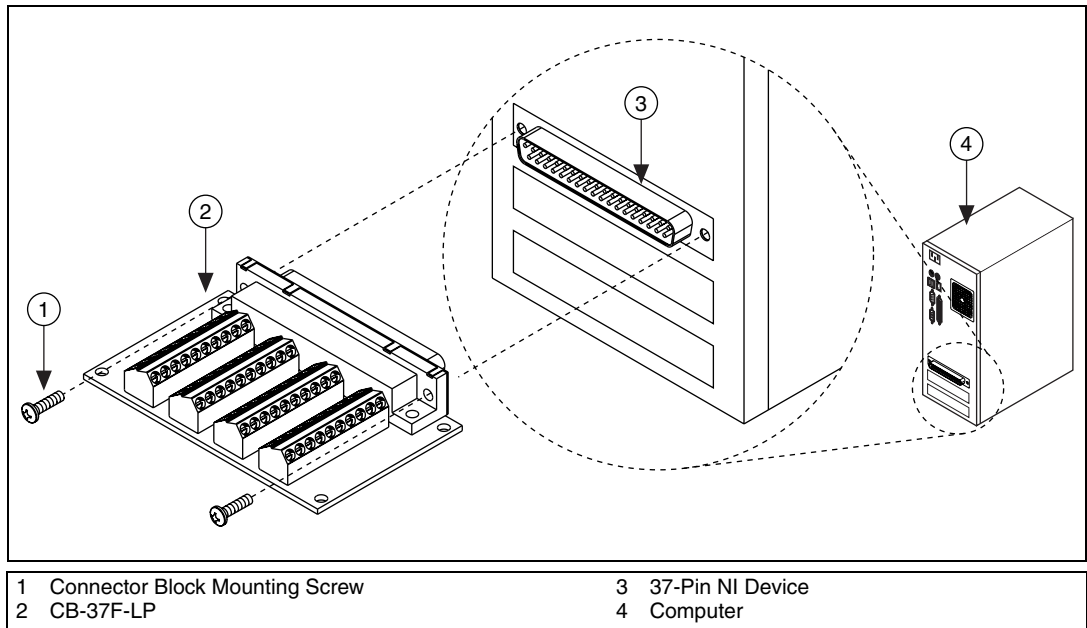

Figure 3. Mounting the CB-37F-LP to a 37-Pin Device



Caution The connectors of both the PCI device and the connector block are polarized. You can attach them in only one way. Do *not* force the connector block when inserting it into or removing it from the PCI device I/O connector. Make sure that the computer is powered off before inserting the PCI device.

1. Install the PCI device into the computer as described in the *DAQ Quick Start Guide*. You must install the CB-37F-LP connector block on the PCI device *after* the device is installed in the computer.



Caution The CB-37F-LP is not designed for input voltages greater than 42 V_{pk}, even if you install a voltage divider that reduces the voltage to within the input range of the DAQ device. Input voltages greater than 42 V_{pk} can damage the CB-37F-LP, any device connected to it, and the host computer. Overvoltage also can cause an electric shock hazard for the operator. National Instruments is *not* liable for damage or injury resulting from such misuse.

2. Install the CB-37F-LP on the PCI device by screwing in both connector block mounting screws with the Phillips screwdriver.

Cabling the Connector Block to the Device

If you do not mount the connector block to the PCI device, you must use a cable to connect the CB-37F-LP to the device. Refer to Figure 4 as you complete the following steps to connect the connector block to the PCI device I/O connector.

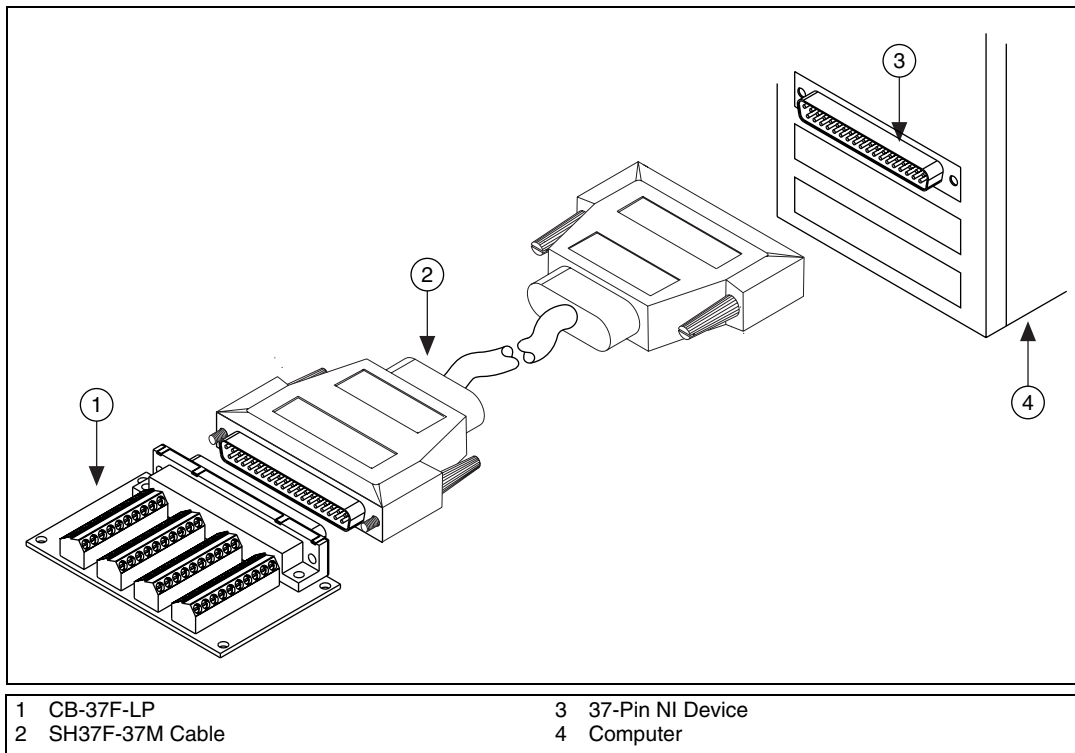

Figure 4. Connecting the CB-37F-LP to a 37-Pin Device with a Cable



Caution The connectors of both the PCI device and the connector block are polarized. You can attach them in only one way. Do *not* force the cable when inserting it into or removing it from the PCI device I/O connector or the CB-37F-LP. Make sure that the computer is powered off before inserting the PCI device.

1. Install the PCI device into the computer as described in the *DAQ Quick Start Guide*. You must make the connection between the CB-37F-LP and PCI device *after* the device is installed in the computer.
2. Connect the SH37F-37M cable to the PCI device I/O connector.
3. Connect the other end of the cable to the CB-37F-LP connector.



Caution The CB-37F-LP is not designed for input voltages greater than 42 V_{pk}, even if you install a voltage divider that reduces the voltage to within the input range of the DAQ device. Input voltages greater than 42 V_{pk} can damage the CB-37F-LP, any device connected to it, and the host computer. Overvoltage also can cause an electric shock hazard for the operator. National Instruments is *not* liable for damage or injury resulting from such misuse.

Specifications

This section lists the specifications of the CB-37F-LP. These specifications are typical at 25 °C unless otherwise specified.

Input/Output

Refer to the documentation for your NI PCI-6010 device to determine the input/output specifications for your application.

Physical

Dimensions.....	5.733 × 8.113 × 1.417 cm (2.257 × 3.194 × 0.558 in.)
I/O connector.....	One 37-pin female D-Sub connector
Screw terminals	
Number	40
Type	Angled entry, 3.91 mm pitch

Environment

Operating temperature.....	0 to 55 °C
Storage temperature	-20 to 70 °C
Relative humidity	10 to 90% noncondensing
Pollution Degree	2
Altitude.....	2,000 m
Indoor use only.	

Safety

This product is designed to meet the requirements of the following standards of safety for electrical equipment for measurement, control, and laboratory use:

- IEC 61010-1, EN 61010-1
- UL 61010-1
- CAN/CSA-C22.2 No. 61010-1



Note For UL and other safety certifications, refer to the product label, or visit ni.com/certification, search by model number or product line, and click the appropriate link in the Certification column.

Where to Go for Support

The National Instruments Web site is your complete resource for technical support. At ni.com/support you have access to everything from troubleshooting and application development self-help resources to email and phone assistance from NI Application Engineers.

National Instruments corporate headquarters is located at 11500 North Mopac Expressway, Austin, Texas, 78759-3504. National Instruments also has offices located around the world to help address your support needs. For telephone support in the United States, create your service request at ni.com/support and follow the calling instructions or dial 512 795 8248. For telephone support outside the United States, contact your local branch office:

Australia 1800 300 800, Austria 43 0 662 45 79 90 0,
Belgium 32 0 2 757 00 20, Brazil 55 11 3262 3599,
Canada 800 433 3488, China 86 21 6555 7838,
Czech Republic 420 224 235 774, Denmark 45 45 76 26 00,
Finland 385 0 9 725 725 11, France 33 0 1 48 14 24 24,
Germany 49 0 89 741 31 30, India 91 80 51190000,
Israel 972 0 3 6393737, Italy 39 02 413091, Japan 81 3 5472 2970,
Korea 82 02 3451 3400, Lebanon 961 0 1 33 28 28,
Malaysia 1800 887710, Mexico 01 800 010 0793,
Netherlands 31 0 348 433 466, New Zealand 0800 553 322,
Norway 47 0 66 90 76 60, Poland 48 22 3390150,
Portugal 351 210 311 210, Russia 7 095 783 68 51,
Singapore 1800 226 5886, Slovenia 386 3 425 4200,
South Africa 27 0 11 805 8197, Spain 34 91 640 0085,
Sweden 46 0 8 587 895 00, Switzerland 41 56 200 51 51,
Taiwan 886 02 2377 2222, Thailand 662 992 7519,
United Kingdom 44 0 1635 523545

National Instruments, NI, ni.com, and LabVIEW are trademarks of National Instruments Corporation. Refer to the *Terms of Use* section on ni.com/legal for more information about National Instruments trademarks. Other product and company names mentioned herein are trademarks or trade names of their respective companies. For patents covering National Instruments products, refer to the appropriate location: **Help»Patents** in your software, the `patents.txt` file on your CD, or ni.com/patents.